



Architectural thinking.

A company founded by architects, PANELITE is committed to developing new, structurally efficient solutions to building with translucency. Our panels are based on a honeycomb sandwich construction typically exploited in the aerospace industry for its high strength to weight ratio and excellent resistance to deflection, with the added benefit of light-transmission. While our standard panel systems are simple to design with and install, our Design Consultants also work closely with our clients to realize complex custom projects.

Clockwise from top left: 1. D+L Loft, New York, NY • Design: Archi-tectonics • Photography: James Wilkins 2. The Brig, Venice CA • Design: John Friedman Alice Kimm Architects • Photography: Benny Chan 3. IIT McCormick Tribune Campus Center, Chicago IL • Design: OMA • Photography: Floto + Warner, Graphics: 2 x 4 4. IIT McCormick Tribune Campus Center, Chicago IL • Design: OMA • Photography: Floto + Warner 5. Mott Street Loft, New York NY • Design: MESH architectures • Photography: Frank Oudeman

www.panelite.us

NY : 212.947.8292
LA : 323.297.0115

PANELITE
©2007 PANELITE LLC



03 - 04

USER'S GUIDE TO PANELITE

Product Selector

How to read Panelite™ product codes

What to expect when ordering Panelite™ panels

05

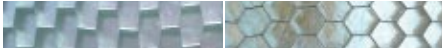

LAMINATED SERIES PANELS

Panelite's lightest weight translucent honeycomb panel, composed of pre-fabricated fiberglass sheet facings laminated to structural honeycomb cores.

Recommended uses for Laminated Series panels:

- vertical wall applications including partitions, backlit walls, atrium walls, feature walls
- doors: sliding, pivoting, hinged
- signage panels
- ceiling panels of modules up to 48" x 120"
- vertical furniture elements including privacy screens and counter fronts

06 - 07



CAST POLYMER SERIES PANELS

Translucent facings are cast directly onto the honeycomb cores to produce our strongest and most versatile translucent honeycomb panel.

Recommended uses for Cast Polymer Series panels:

- vertical wall applications including partitions, backlit walls, atrium walls, feature walls
- doors: sliding, pivoting, hinged
- signage panels
- ceiling panels of modules up to 48" x 120"
- furniture applications such as countertops, desks, tables, shelves, privacy screens
- light load-bearing applications, i.e., display pedestals
- interlocking wall elements using Panelite's proprietary ITL installation system. See page 13 for details.

08 - 09

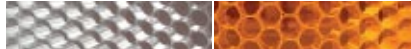

CLEARSHADE™ IGU SERIES

Exterior-grade, non-combustible insulating glass units panels composed of glass-facings and tubular honeycomb core. Can be customized to meet a broad range of performance criteria.

Recommended uses for ClearShade™ IGU:

- exterior façade panels
- sloped exterior glazing and canopies
- interior vertical wall applications including partitions, backlit walls, atrium walls, feature walls

10



SHEET LAMINATES

Mica or directionally woven Glass Cloth layers are laminated with binding resins to produce textured, translucent sheet laminates.

Recommended uses for Panelite™ Sheet Laminates:

- vertical wall applications including partitions, backlit walls, feature walls
- ceiling panels
- furniture applications such as bar fronts, inlay pieces, privacy screens

11 - 12

PFS : PANELITE INSTALLATION SYSTEM

This storefront-type glazing system can be pre-fabricated to order or shipped in stock lengths and is compatible with all Panelite™ honeycomb panels.

Recommended uses for the PFS framing system:

- interior vertical wall applications where ease of installation and ability to remove panels are considerations
- system options do not include curves, or doors.

13 - 15

ITL: PANELITE INSTALLATION SYSTEM

Panelite's interlocking installation system, pre-fabricated to order and compatible with Panelite™ Cast Polymer Series panels.

Recommended uses for the ITL framing system:

- interior vertical walls and free-standing elements
- system options include curved elements and doors

- 02 index
- 03 user guide
- 04 product selector
- 05 laminated series
- 06 cast polymer
- 07 CPS custom
- 08 IGU series
- 09 IGU technical
- 10 sheet laminates
- 11 PFS framing
- 12 PFS details
- 13 ITL framing
- 14 ITL details
- 15 ITL details
- 16 contact
- 17 distributors

www.panelite.us

NY : 212.947.8292
LA : 323.297.0115

PANELITE
©2007 PANELITE LLC



READING PANELITE PRODUCT CODES

All Panelite product codes are constructed as acronyms that refer to the product's composition.

Honeycomb panel product codes are constructed as follows:
[Honeycomb core material] / [Facing type] [Facing color]

HONEYCOMB CORE MATERIALS:



AH
Aluminum Hexagonal



AO
Aluminum Over-expanded



PE
Polymer



TC
Tubular

FACING TYPE:



Laminated Series product codes indicate either Fiberglass **[F]** facings or Glass Cloth Laminate **[GCL]** facings

AH/**FC** = Aluminum Hexagonal / Fiberglass Clear

AO/**FB** = Aluminum Over-expanded / Fiberglass Blue

AO/**GCL** = Aluminum Over-expanded / Glass Cloth Laminate

Standard colors for Laminated Series panels: Clear, Light Blue, Light Green



Cast Polymer Series product codes indicate Resin **[R]** facings.

AO/**RM** = Aluminum Over-Expanded / Resin Magenta

PE/**RC** = Polymer / Resin Clear

Standard colors for Cast Polymer panels: Clear, Dark Blue, Blue, Very Light Blue, Green, Yellow, Orange, Magenta, Red, Dark Red.



ClearShade™ IGU Series codes start with "**IGU**" and follow with the core type and cell diameter

IGU/TC-4 = Insulating Glass Unit / Tubular Clear core, 1/4" cell diameter

IGU/TO-8 = Insulating Glass Unit / Tubular Orange core, 1/8" cell diameter

Standard colors for IGU panels:

Glass: Clear, Grey, Bronze, Light Green, Light Blue

Core: Clear, Orange. **Special order:** White, Black, Bright Green, Bright Blue, Magenta



Sheet Laminates use descriptive acronyms:

GCL = Glass Cloth Laminate

MLS = Mica Laminate Silver

MLA = Mica Laminate Amber

Standard colors for Sheet Laminates: Amber (MLA), Silver (MLS), Light Green (GCL)

WHAT TO EXPECT WHEN ORDERING PANELITE PANELS

Light transmission and visual privacy.

Panelite's product lines offer varying degrees of light transmission and visual privacy, from the most translucent IGU series to the least translucent Cast Polymer Series and Sheet Laminates.

High strength-to-weight ratio.

Due to their integral honeycomb core, Panelite™ panels are extremely stiff and lightweight, and require minimal structural framing.

Note: high strength to weight ratio is not applicable to Panelite Sheet Laminates or Insulating Glass Units.

Architectural thinking.

Panelite is a company founded by architects. Every project is approached from an architectural standpoint and every product development is motivated by the goal of expanding the range and purpose of translucency in building.





Organic aesthetic.

Each panel is the exact expression of its production process and component materials, which are fluid or flexible in nature. Our honeycomb cores are so lightweight that they have the suppleness of textile before they are bonded to translucent facings to form extremely stiff composite panels. Some of our panel facings are cast and retain the viscous appearance of their original liquid state. The fluid nature of these materials yields a dynamic aesthetic, similar to the grain of wood or the texture of marble.

- 02 index
- 03 user guide
- 04 product selector
- 05 laminated series
- 06 cast polymer
- 07 CPS custom
- 08 IGU series
- 09 IGU technical
- 10 sheet laminates
- 11 PFS framing
- 12 PFS details
- 13 ITL framing
- 14 ITL details
- 15 ITL details
- 16 contact
- 17 distributors



USER'S GUIDE TO PANELITE: PRODUCT SELECTOR

	LAMINATED SERIES	CAST POLYMER SERIES	CLEARSHADE™ IGU	SHEET LAMINATES
BASIC COMPOSITION				
	Pre-fabricated translucent fiber-glass sheet facings laminated to structural honeycomb cores made of aluminum or polymers.	Translucent resin facings cast directly onto structural honeycomb cores made of aluminum or polymers.	Exterior-grade, non-combustible panels composed of glass facings and tubular polycarbonate honeycomb core.	Translucent sheet laminates of Mica or directionally woven Glass Cloth with resin binders.
PERFORMANCE/AESTHETIC CRITERIA				
Exterior use	-	-	Yes	-
Class C fire rating	Yes	For flame spread only	Yes	MLA
Class A fire rating	AO/GCL only	-	Yes	MLS, GCL
Integral edge option	-	Yes	-	GCL
Curving	-	Yes – curved in production only	-	GCL: cold curved on site only MLA/MLS: thermo-formed or cold-curved
Standard Colors	Clear, Light blue, Light green	Clear, Dark Blue, Blue, Very Light Blue, Green, Yellow, Orange, Magenta, Red, Dark Red.	Glass: Clear, Grey, Bronze, Light Green, Light Blue Core: Clear, Orange, White, Black, Bright Green, Bright Blue, Magenta. (longer lead times and min. orders apply to colored cores and glass)	Amber (MLA), Silver (MLS), Light Green (GCL)
Custom colors	Yes, minimum order 2500 sf	Yes, no minimum order	Yes, both glass and core. Minimum order 2000 sf.	-
Easy to cut, drill, machine on site	Yes	Yes	-	Yes
Pre-fabricated elements built to order	-	Yes	-	-
RELATIVE CHARACTERISTICS				
Stiffness	High	High	Medium	Low
Light transmission	High	Medium	High	Medium
Privacy	Medium	High	Medium - Low	High
Sound transmission	Medium	Low	Low (produced to specification)	High
Weight	Low (1psf)	Medium (2.5psf)	High (7 psf)	Medium (1-3 psf)
APPLICATIONS				
Walls	Yes	Yes	Yes	Yes
Doors	Yes	Yes	Yes	Yes, with additional framing
Ceilings	Yes	Yes	Yes	Yes
Facades	-	-	Yes	-
Wet applications (shower, sauna)	Yes	Yes	Yes	GCL only
Furniture	Yes – vertical surfaces and inlays	Yes	-	Yes – as vertical surfaces, laminates and inlays
Light load-bearing (work, dining, display surfaces)	-	Yes	-	-
Recommended Installation system	Panelite™ PFS or custom detailed	Panelite™ ITL or Panelite™ PFS	Interior: Panelite™ PFS. Exterior: Compatible with all commercially available curtain wall systems	Wood or Metal Framing; solid substrate such as GWB or plywood

- 02 index
- 03 user guide
- 04 product selector
- 05 laminated series
- 06 cast polymer
- 07 CPS custom
- 08 IGU series
- 09 IGU technical
- 10 sheet laminates
- 11 PFS framing
- 12 PFS details
- 13 ITL framing
- 14 ITL details
- 15 ITL details
- 16 contact
- 17 distributors

www.panelite.us

NY : 212.947.8292
LA : 323.297.0115

PANELITE
©2007 PANELITE LLC



LAMINATED SERIES

Panelite™ Laminated Series panels consist of pre-fabricated fiberglass facings laminated to a structural honeycomb core. At only 1 pound per square foot, they are the lightest weight honeycomb panel in the Panelite™ line, and their inherent stiffness allows for minimal installation details without the need for additional structural members. They are ideal for such applications as vertical walls, ceilings, signage, sliding and pivoting doors.

CORE OPTIONS

- [AH] aluminum hexagonal, 3/8" diameter cell
- [AO] aluminum over-expanded, 3/8" x 5/8" cell
- [TC] tubular polycarbonate honeycomb, clear, 1/4" cell
- [TO] tubular polycarbonate honeycomb, clear, 1/4" cell

FACING OPTIONS

- [FC] clear fiberglass
- [FB] blue fiberglass
- [GCL] glass cloth laminate

PANEL DIMENSIONS

- [AH] type: 48" x 96" x 0.75", 48" x 120" x 0.75"
- [AO] type: 48" x 96" x 0.75", 48" x 120" x 0.75"
- [TC] core: 48" x 96" x 0.75", 48"x120" x 0.75"v
- [AO/GCL] panel: 48" x 96" x 0.715"

FIRE RATING

- [AH/F*], [AO/F*] type panels: Class C per ASTM E-84
- [AO/GCL] panel: Class A per ASTM-E84

US Patent No. 6,500,516
Please consult Panelite's installation specifications under "specifications" at www.panelite.us for complete handling, installation and technical information.

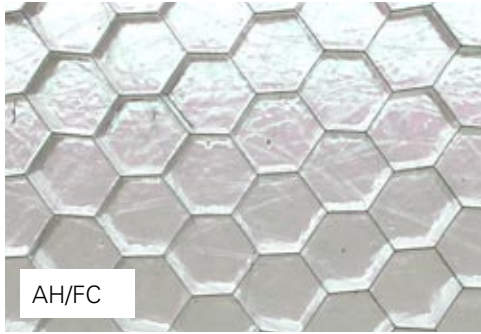

AH/FC

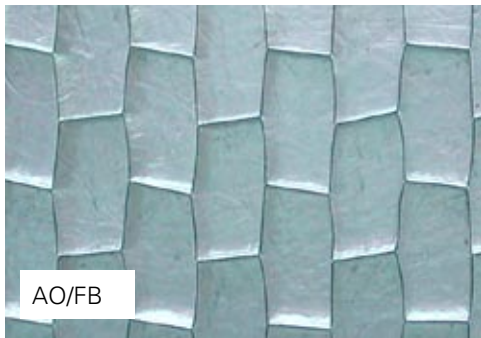

AO/FB



TC/FC



AO/GCL

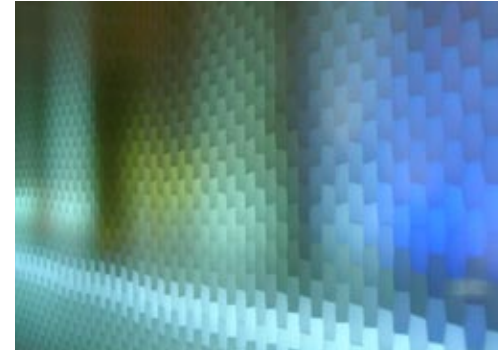

PANELITE™ AO/GCL • Vucciria bar, Milwaukee, WI
Design: Flux Design • Photography: Flux Design



PANELITE™ AH/FC • Valentine Group offices, New York NY
Design: MR Architecture + Décor • Photography: Martyn Thompson



PANELITE™ AH/FC with vinyl graphics • StoryCorps StoryBooth, Grand Central Terminal, New York, NY
Design: MAS design and MESH architectures
Graphics: ORG inc. • Photography: Christopher Weil

- 02 index
- 03 user guide
- 04 product selector
- 05 laminated series
- 06 cast polymer
- 07 CPS custom
- 08 IGU series
- 09 IGU technical
- 10 sheet laminates
- 11 PFS framing
- 12 PFS details
- 13 ITL framing
- 14 ITL details
- 15 ITL details
- 16 contact
- 17 distributors



CAST POLYMER SERIES

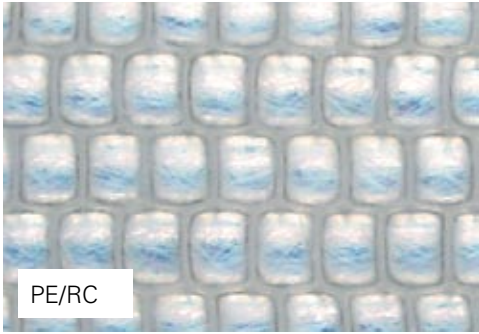

PE/RC

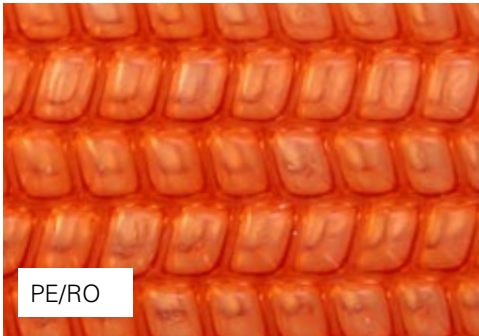

PE/RO

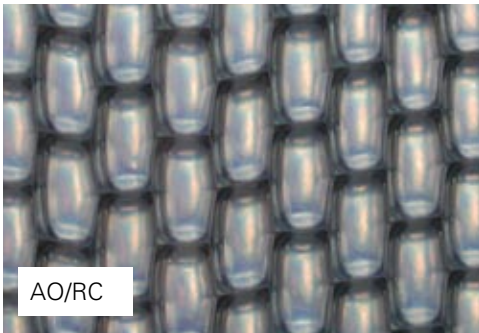

AO/RC

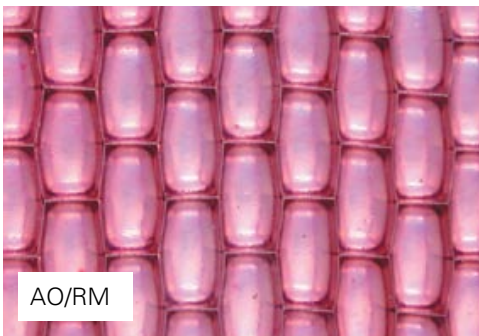

AO/RM

Panelite™ Cast Polymer Series panels use the same honeycomb core technology as Laminated Series panels, but instead of using pre-fabricated facings laminated to the honeycomb, facings are cast directly onto the cores. Although the casting process yields a slightly heavier panel, at 2.5 pounds per square foot, it also provides a much stronger core to facing bond while maintaining an excellent strength to weight ratio. This makes the Cast Polymer panels ideal for a wide range of applications, including light load bearing and furniture applications, vertical walls, doors, and ceilings.

Cast Polymer Series panels offer the greatest design versatility of the Panelite™ range. Please see the full list of custom options on the following page.

CORE OPTIONS:

[AO] aluminum over-expanded, 3/8" x 5/8" cell
 [PE] woven grid polymer honeycomb, 3/8" cell

FACING OPTIONS:

[RC] untinted polyester resin
 [R*] tinted polyester resin

STANDARD COLORS:

Clear (C)	Magenta (M)
Blue (B)	Orange (O)
Very Light Blue (VLB)	Green (G)
Dark Blue (MUB)	CUSTOM COLORS:
Red (R)	provide Pantone®
Dark Red (VFR)	number or color chip

PANEL DIMENSIONS

[PE] core: 46" x 96", 46" x 120" standard
 [AO] core: 48" x 96", 48" x 120" standard

PANEL THICKNESS:

1" or 1-1/2" standard
 Custom thicknesses are subject to availability.

US Patent No's: D498,8565; D489,1405; D488,8725;
 D489,1415; D489,1425

Please consult Panelite's installation specifications under "specifications" at www.panelite.us for complete handling, installation and technical information.



PANELITE™ AO/RC • Conwert Immobilien offices, Vienna, Austria • Design: Heinz Lutter (www.lutter.at)
 Photography: Margherita Spiluttini



PANELITE™ AO/RCIT • McCormick Tribune Campus Center, Chicago IL • Design: OMA • Photography: Panelite



PANELITE™ AO/RC • D+L LOFT, New York, NY
 Design: Archi-tectonics • Photography: Panelite

- 02 index
- 03 user guide
- 04 product selector
- 05 laminated series
- 06 cast polymer
- 07 CPS custom
- 08 IGU series
- 09 IGU technical
- 10 sheet laminates
- 11 PFS framing
- 12 PFS details
- 13 ITL framing
- 14 ITL details
- 15 ITL details
- 16 contact
- 17 distributors



CAST POLYMER SERIES

CUSTOM OPTIONS:

CURVED PANELS

Standard radii include: 12", 24", 60", 96"

Custom radii: produced per project

Note: All curved panels are made to order, but panels with standard radii are more cost- and time-efficient to produce. Please inquire regarding standard radii as we continually expand our mold library.

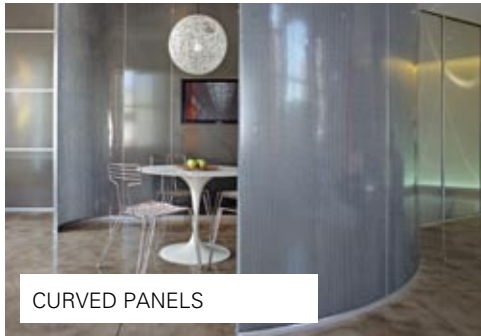

CURVED PANELS

EDGE OPTIONS

Integral 90° resin edges expose the honeycomb core while providing a strong, self-sealed edge. Also available on "inside" edges, e.g. sink cutouts. Alternately, 1/8" aluminum flat bar makes a minimal edge detail that conceals the honeycomb core.

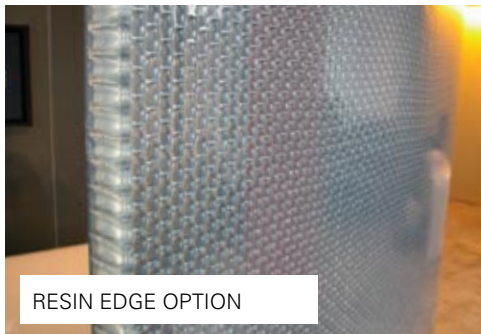

RESIN EDGE OPTION

CUSTOM FABRICATION

Panelite has the capability to pre-fabricate Cast Polymer Series panels in a variety of ways, using cutting, edging and bonding techniques to produce custom furniture, display or feature elements.



CUSTOM FABRICATION

ITL INSTALLATION SYSTEM

Panelite has developed a proprietary system for the installation of Cast Polymer Panels. An interlocking detail takes advantage of the panels' inherent structure to achieve a minimal installation detail for assembling walls and free-standing elements.

See p. 13 for full details.



ITL INSTALLATION SYSTEM

CURVED PANELS:

PANELITETM AO/RVLB with ITL • Panelite New York Showroom, New York, NY • Design: Panelite • Photography: Floto + Warner

CUSTOM FABRICATION:

PANELITETM AO/RO with ITL • Georgia Aquarium, Atlanta, GA
Design: TVS Interiors • Photography: Brian Gassel of TVS Interiors

Please consult Panelite's installation specifications under "specifications" at www.panelite.us for complete handling, installation and technical information.

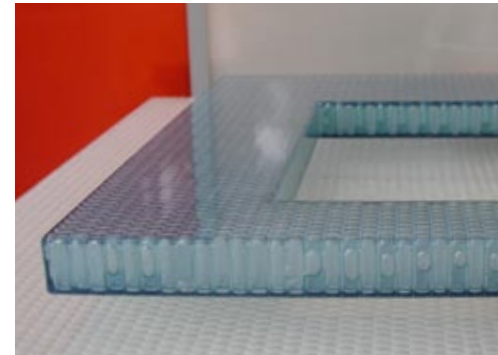

PANELITETM PE/RB • Countertop with cutouts for sink, "inside" and "outside" resin edges
Photography: Panelite

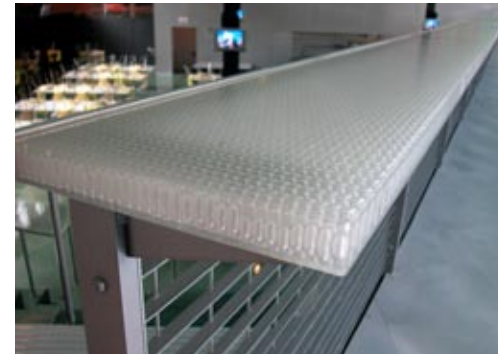

PANELITETM PE/RC counter with resin edge
IIT McCormick Tribune Campus Center, Chicago IL
Design: OMA • Photography: Panelite



PANELITETM PE/RC double-curved counter with ITL
Drom Fragrance Bar, New York, NY
Design: Janko Rasic Architects • Photography: Panelite

- 02 index
- 03 user guide
- 04 product selector
- 05 laminated series
- 06 cast polymer
- 07 CPS custom
- 08 IGU series
- 09 IGU technical
- 10 sheet laminates
- 11 PFS framing
- 12 PFS details
- 13 ITL framing
- 14 ITL details
- 15 ITL details
- 16 contact
- 17 distributors



CLEARSHADE™ IGU SERIES

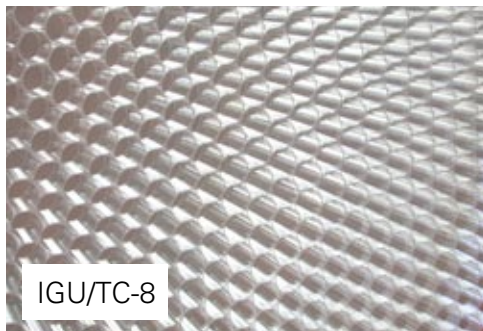

IGU/TC-8

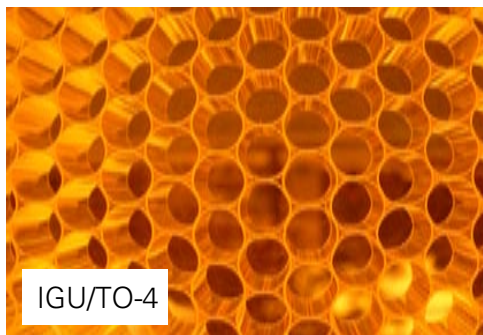

IGU/TO-4

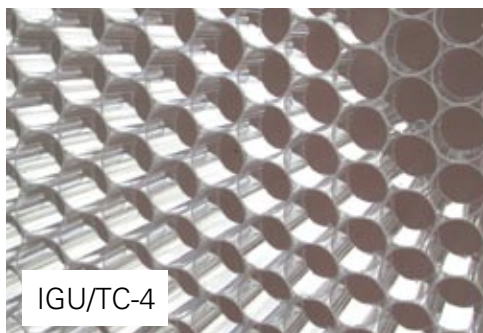

IGU/TC-4

The Panelite ClearShade™ insulating glass unit was developed for exterior glazing applications using a tubular honeycomb core with patented polymer technology that offers superior shading performance. In addition to the benefits of visual privacy and a Visible Light Transmittance of up to 50%, the ClearShade™ IGU achieves a Solar Heat Gain Coefficient of 0.18 at midday, approximately 75% lower than that of other insulating glass units without the need for tinted, reflective or specialty glass. This dramatically reduces climate control requirements and results in significant energy savings over the life of the building.

The ClearShade™ IGU may be customized to meet a broad range of performance and aesthetic requirements.

PANEL COMPOSITION

STANDARD UNIT COMPOSITION:

- 1" overall unit thickness
- INBOARD LITE: 1/4" clear tempered glass
- INTERIOR: 1/2" airspace with Panelite ClearShade™ honeycomb core
- OUTBOARD LITE: 1/4" clear tempered glass

CORE OPTIONS: TUBULAR POLYCARBONATE HONEYCOMB

- Cell diameter: 1/8" or 1/4"
- Standard core thickness: 1/2"
- Standard colors: Clear, Orange
- Special order: White, Black, Bright Green, Light Blue, Blue, Raspberry. All colors UV-stabilized. Longer lead times and minimum orders apply to colored cores and glass.

FACING OPTIONS: GLASS LIGHT

- Laminated (1/4", 5/16", 3/8", 7/16", 1/2" and 9/16")
- Tempered (3/16", 1/4", 3/8" and 1/2")
- Custom colored PVB interlayer (laminated glass only).
- Standard Glass colors: bronze, grey, green, blue, and white
- Acid-etched, low-e coated glass
- Ceramic frit patterns

PANEL DIMENSIONS:

- Units are produced to specified dimensions per project
- Maximum dimensions 48" x 120"
- Panel thickness is subject to unit composition

MINIMUM ORDER: 500 SF for standard units
2000 SF for colored core units



PANELITETM IGU/TO-4 • IIT McCormick Tribune Campus Center, Chicago IL • Design: OMA, Photography: Floto + Warner, Graphics: 2 x 4

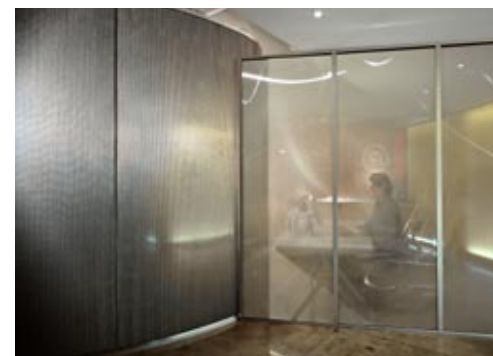

PANELITETM AO/RVLB, IGU/TC-8 • Panelite New York Showroom, New York, NY • Design: Panelite, Photography: Floto + Warner



PANELITE™ IGU/TX-4 • Falcón Headquarters, Mexico City, Mexico • Design: Rojkind Arquitectos
Photography: Panelite

- 02 index
- 03 user guide
- 04 product selector
- 05 laminated series
- 06 cast polymer
- 07 CPS custom
- 08 IGU series
- 09 IGU technical
- 10 sheet laminates
- 11 PFS framing
- 12 PFS details
- 13 ITL framing
- 14 ITL details
- 15 ITL details
- 16 contact
- 17 distributors

www.panelite.us

NY : 212.947.8292
LA : 323.297.0115

PANELITE
©2007 PANELITE LLC



US Patent Pending

Please consult Panelite's installation specifications under "specifications" at www.panelite.us for complete handling, installation and technical information.

CLEARSHADE™ IGU SERIES

TECHNICAL PERFORMANCE

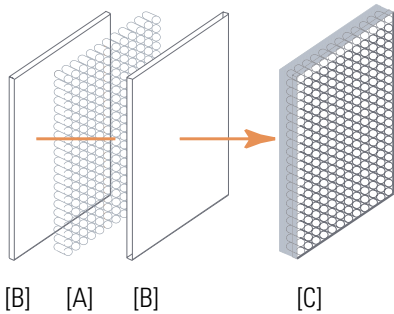

- [A] tubular honeycomb core
- [B] glass facings
- [C] core + facings + spacer/seal = hermetically sealed unit

	PANELITE IGU	NON-PANELITE TYPICAL IGU	TYPICAL IGU w/ LOW-e
Winter U Value	.47	.49	.33
Shading Coefficient	.77	.84	.78
Solar Heat Gain Coefficient	.67	.72	.67
R Value	2.12	2.00	3.00

Tests based on a standard PANELITE IGU, 1" overall thickness: 3/16" tempered glass (inboard + outboard lites) + 5/8" thick clear tubular core (1/4" cell).
 *PANELITE offers customized units for thermal performance per project requirements.

THERMAL PERFORMANCE:

See chart at left for comparative thermal performance of standard unit. For increased insulating properties, Panelite can provide low-e coatings and/or argon filled units.

STC RATING (ACOUSTICAL): 31

While the standard ClearShade™ IGU already provides an excellent sound barrier, specified STC requirements can be met by adjusting the glass composition and airspace/core ratio.

FIRE RATING:

Class A, non-combustible

WIND LOAD

Up to hurricane force wind-load requirements may be met using specifically designed glass composition

CERTIFICATION:

Developed, manufactured and tested in accordance with IGCC and ISO 9001:2000 specifications, the ClearShade™ IGU is certified for both exterior and interior applications. A dual-seal construction, IGCC certified and CBA rated, provides excellent resistance to MVT (moisture vapor transmittance) and to UV degradation. All glass used in Panelite™ IGU fabrication is tested and certified per ASTM1036 [float glass], ASTM 1048 [heat treated, tempered glass] and SGCC (heat-treated glass.)

INSTALLATION:

Panelite IGU's are compatible with most commercially available storefront and curtainwall systems

The Panelite ClearShade™ IGU carries a 10-year limited liability warranty. Please inquire regarding project-specific technical requirements.

US Patent Pending

Please consult Panelite's installation specifications under "specifications" at www.panelite.us for complete handling, installation and technical information.



PANELITETM IGU/TX-4 with custom orange glass and ceramic frit graphics • IIT McCormick Tribune Campus Center, Chicago IL • Design: OMA, Photography: Panelite



PANELITETM IGU/TO-4 • IIT McCormick Tribune Campus Center, Chicago ILs • Design: OMA, Photography: Floto + Warner

- 02 index
- 03 user guide
- 04 product selector
- 05 laminated series
- 06 cast polymer
- 07 CPS custom
- 08 IGU series
- 09 IGU technical
- 10 sheet laminates
- 11 PFS framing
- 12 PFS details
- 13 ITL framing
- 14 ITL details
- 15 ITL details
- 16 contact
- 17 distributors

www.panelite.us

NY : 212.947.8292
 LA : 323.297.0115

PANELITE
 ©2007 PANELITE LLC



PANELITE LAMINATES

MICA LAMINATES [MLA, MLS] GCL CLOTH LAMINATES [GCL]

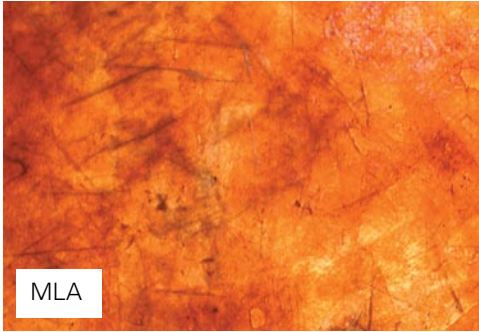

MLA



MLS



GCL

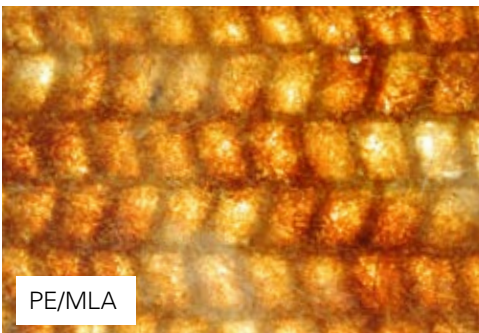

PE/MLA

Mica laminates are composed of natural mica splittings bound with fiberglass and shellac or vinyl resins. Workable with standard carpentry tools, they can be used as translucent infill panels or mounted to a solid substrate (plywood, GWB). Mica panels can be cold-curved (MLS, MLA) or thermoformed (MLA) on site.

Glass Cloth Laminates consist of directionally woven glass cloth layers bound with epoxy resin. A thermoset material with excellent impact strength, it can be cold-curved and very precisely cut, drilled, and machined.

LAMINATE OPTIONS

[MLA] mica splittings with shellac resin.
[MLS] mica splittings with alkyd vinyl resin.
[GCL] directionally woven fiberglass cloth with epoxy resin

COLORS

[MLA] amber
[MLS] silver
[GCL] natural pale green

PANEL DIMENSIONS:

[MLA], [MLS]: 36" x 72" x 0.03"
Custom thicknesses (0.02" to 0.06") also available.
[GCL]: 48" x 96" x 0.125"
Custom thicknesses (0.06" to 2") also available.
GCL sheets up to 0.125" thick can be cold-curved

FIRE RATING

[MLA] Class C per ASTM E-84
[MLS] Class A per ASTM E-84
[GCL] Class V-0 per UL94

COMPOSITE OPTIONS:

PE/MLA, PE/MLS: Mica facing bonded to [PE] type Cast Polymer Series panels
AO/MLA, AO/MLS: Mica facing bonded to [AO] type Cast Polymer Series panels
Composite options are custom orders. Lead times, pricing and sample availability may vary

MINIMUM ORDER:
3 SHEETS



PANELITE™ MLA • Greenwich Street loft, New York, NY • Design: Moneo Brock Architects • Photography: Michael Moran



PANELITE™ MLS custom-cut discs • W Hotel Lakeshore, Chicago, IL • Design: W Design Group • Photography: Panelite

- 02 index
- 03 user guide
- 04 product selector
- 05 laminated series
- 06 cast polymer
- 07 CPS custom
- 08 IGU series
- 09 IGU technical
- 10 sheet laminates
- 11 PFS framing
- 12 PFS details
- 13 ITL framing
- 14 ITL details
- 15 ITL details
- 16 contact
- 17 distributors



PANELITE™ PFS: FRAMING SYSTEM

Designed for interior applications, the Panelite™ Framing System is a low-profile, lightweight glazing-type installation system compatible with the full range of Panelite™ panels. Applications include floor to ceiling wall panels, large scale multi-story atrium walls, and complex geometric frame designs.

PANELITE PFS system features:

- Low profile
- Customizable to project specifications
- Can be prefabricated by Panelite to minimize on site labor
- Standard snap-in glazing bead detail is easily installed by glazing professionals
- Shop drawings provided by Panelite for pre-fabricated framing applications
- Full 1-5/8" deep sections with tubular sash and rails will meet or exceed AAMA C50 commercial performance specifications

PANELITE PFS system options:

- Frames may be prefabricated by Panelite with mitered corners (joined with angles inside the frames) and shipped to the job site as "knock-down" frames ready for assembly
- Alternately, Panelite can supply full lengths of system profiles for on-site fabrication
- For simpler framing applications, Panelite offers aluminum "U" channels for cast polymer and laminated series panels, and an "H" channel for laminated series panels only
- Standard finish: clear anodized aluminum
- Panelite offers custom fabrication services such as cutting and framing for cast polymer series panels only. (See pages 06,07,13-15)
- Laminated series panels can be cut and framed on site using standard woodworking tools and adhesives



Please consult Panelite's installation specifications under "specifications" at www.panelite.us for complete handling, installation and technical information.

DETAIL 1:
PFS as seen at ICFF 2003, New York

DETAIL 2:
PFS/AI-G2: Perimeter profile

DETAIL 3:
PFS/A2-G1: Intermediate profile seen from glazed side

DETAIL 4:
PFS/A4+A1-G1: Square corner post and perimeter profile, seen from glazed side

PANELITE™ PFS: FRAMING SYSTEM

PLAN DETAILS

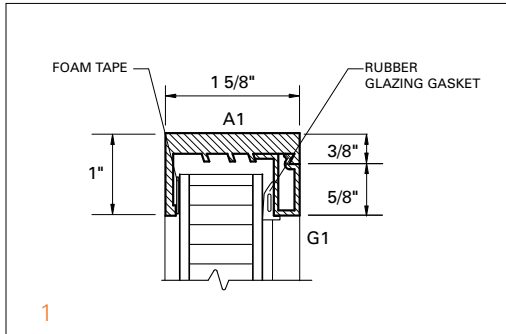

DETAIL 1:

PFS/A1-G1 [A1 perimeter profile + G1 glazing bead for 1" thick panels]

DETAIL 2:

PFS/A2-G1 [A2 'T' intermediate profile + G1 glazing bead]
Neoprene setting blocks should be used for IGU panel installation

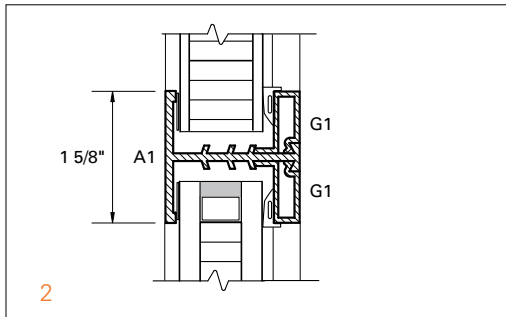

DETAIL 3:

PFS/A3-G1 [A3 narrow "split" tube for vertical and horizontal stacking + G1 glazing bead] Please inquire about structural "split" profiles for large scale installations

DETAIL 4:

PFS/A4 [1-3/4" square corner post] PFS/A1-G2 [A1 + G2 glazing bead for 3/4" thick panels]

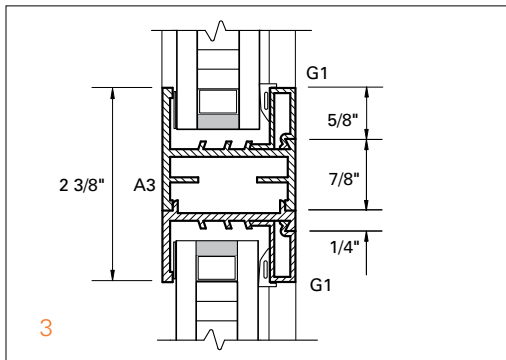

DETAIL 5:

ALU/H [1" H profile with 1/16" wall thickness for 3/4" thick panels]
Fully compatible with Panelite™ Framing System

DETAIL 6:

ALU/C [1/2" U-channel with 1/8" wall thickness for 3/4" panels]
Alternate to Panelite™ Framing System for lighter framing requirements

1/2", 3/4", or 1" leg channels available

Please consult Panelite's installation specifications under "product info" at www.panelite.us for complete handling, installation and technical information.

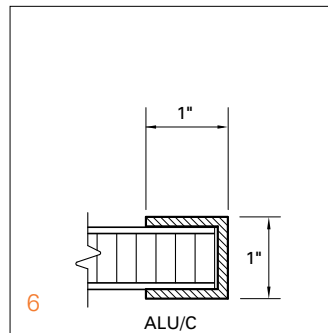
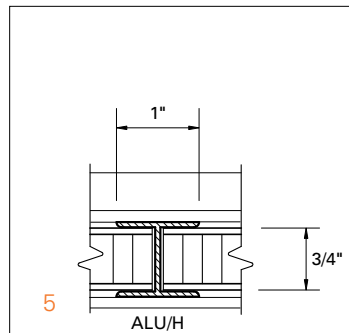
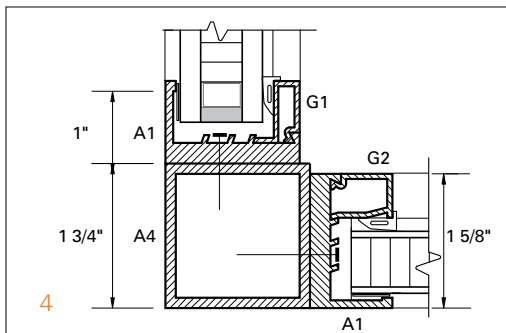

PANELITE™ ITL : INTERLOCKING INSTALLATION SYSTEM

Panelite's new Interlocking "ITL" Fabrication System allows for efficient, low-profile installation of Panelite™'s Cast Polymer Series panels by exploiting the structural properties of the panels' honeycomb core. No additional framing members are required.

All Panelite™ ITL Systems are provided fully pre-fabricated to each project's specifications and are shipped in installation-ready components. Shop Drawings are included and Panelite™ Technical Support is available through design development and installation as well as following completion.

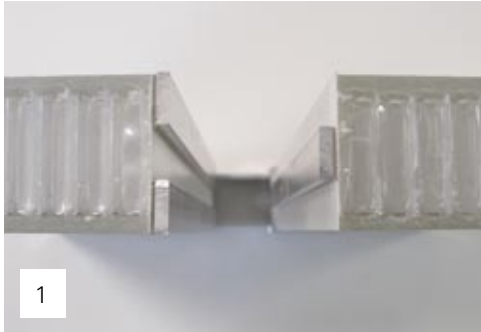

PANELITE™ ITL System Features:

- Compatible with all Panelite™ Cast Polymer panels, flat or curved.
- Self supporting: **no stud framing required**
- Low Profile
- Customizable
- Fully pre-fabricated by Panelite to minimize on site labor
- Easy to install with standard tools
- Shop drawings provided by Panelite for approval

PANELITE™ ITL System options:

- Design development assistance
- Floor to ceiling system options
- Free standing system options
- Aluminum tongue and groove connection for 1.5" thick panels or "H" connector panel joints for 1" thick panels
- Pre-fabricated mitered corners (to any angle) for profile-free corner elements.
- Radiused corner or wall panels
- Hinged doors including lockset
- Sliding Doors including hardware
- Integral Resin edge panel closeout
- Aluminum Edge banding panel closeout

DETAIL 1:

ITL aluminum tongue and groove connection for 1.5" thick panels

DETAIL 2:

ITL aluminum tongue and groove connection for 1.5" thick panels with channel connection at floor (matching channel is used to connect panels at top)

DETAIL 3:

ITL pre-fabricated mitered corner

DETAIL 4:

ITL aluminum H-connector for 1" thick panels and channel connection at floor (matching channel is used to connect panels at top)



PANELITE™ ITL : INTERLOCKING INSTALLATION SYSTEM



PANELITETM AO/RVLB with ITL • Panelite New York Showroom, New York, NY • Design: Panelite
Photography: Floto + Warner

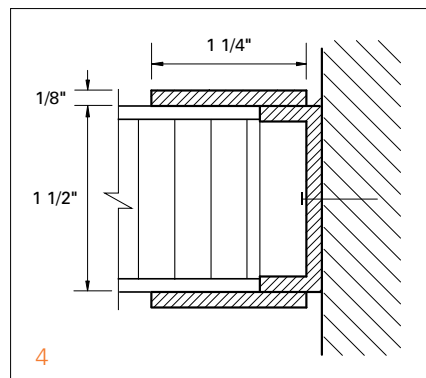
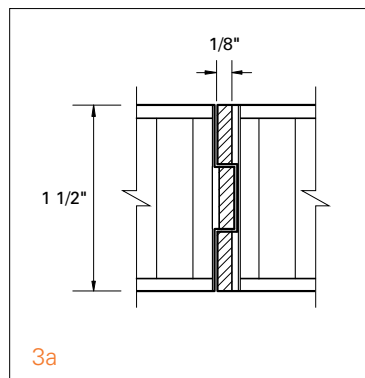
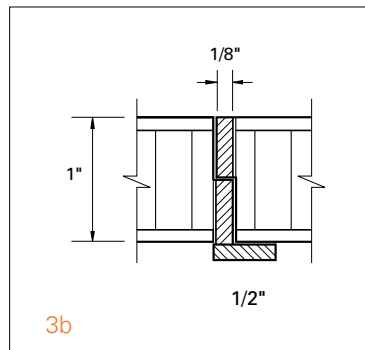
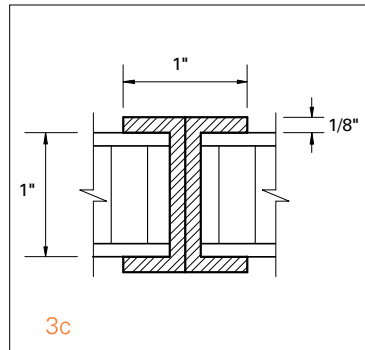
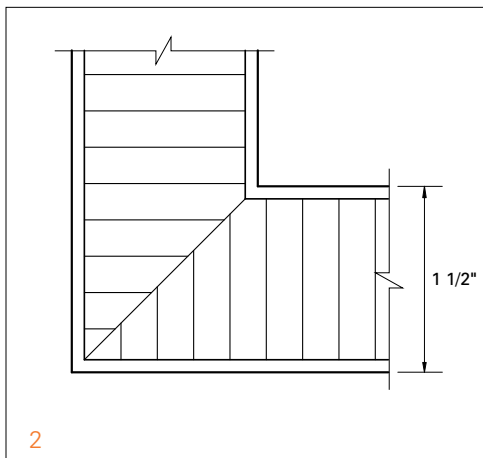
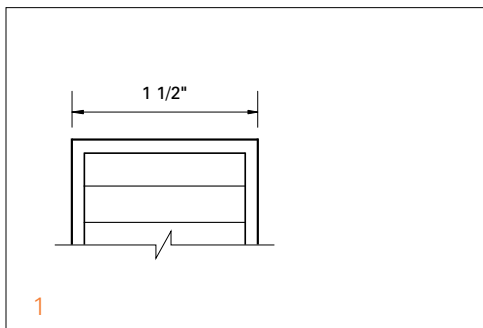

PLAN DETAILS

DETAIL 1:

Panelite integral resin edge. Alternate option: aluminum flat bar endcap pre-attached to panel by Panelite.

DETAIL 2:

Prefabricated mitered corner panel.

DETAIL 3a:

Aluminum tongue and groove connectors for 1.5" thick panels. Rigidly attached to panel edge by Panelite.

DETAIL 3b:

Modified tongue and groove detail for 1" thick panels. Aluminum lap joint with continuous flat bar visible from one side only. Recommended for single-sided applications.

DETAIL 3c:

Aluminum back-to-back channel connector for 1" thick panels.

DETAIL 4:

Aluminum channel (supplied by Panelite) attached to wall prior to Panelite™ panel installation. Contractor to supply appropriate fastener to existing wall.

Please consult Panelite's installation specifications under "specifications" at www.panelite.us for complete handling, installation and technical information.

PANELITE™ ITL : INTERLOCKING INSTALLATION SYSTEM

SECTION DETAILS

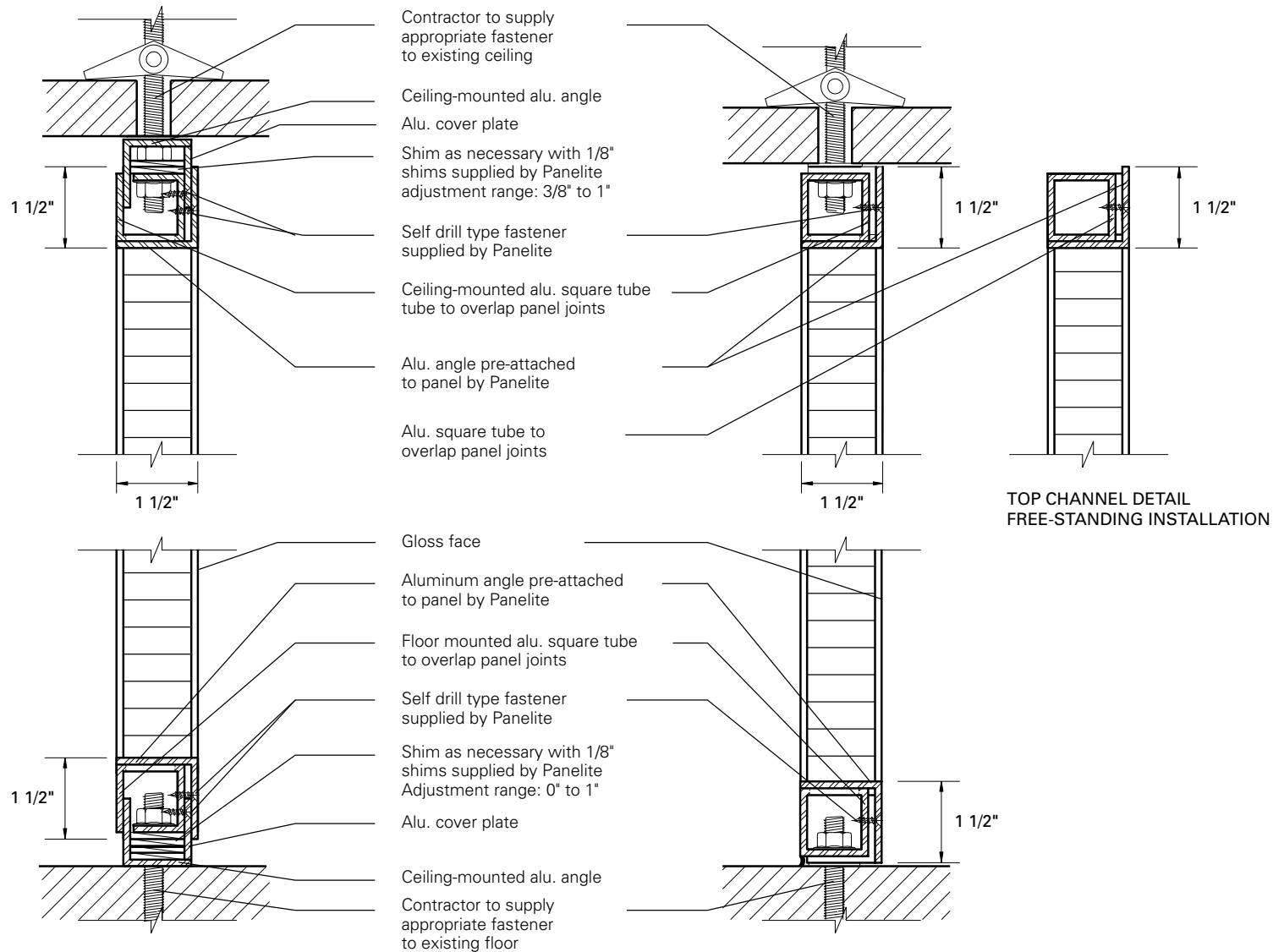

FLOOR TO CEILING INSTALLATION
DETAILS FOR UNEVEN SITE CONDITIONS

FLOOR TO CEILING INSTALLATION
DETAILS FOR LEVEL SITE CONDITIONS

Note: above section details assume 1.5" panels with tongue and groove connections per detail 3a, p. 14. Similar details can be provided for 1" thick cast polymer panels. Please inquire for project-specific detailing.





- 02 index
- 03 user guide
- 04 product selector
- 05 laminated series
- 06 cast polymer
- 07 CPS custom
- 08 IGU series
- 09 IGU technical
- 10 sheet laminates
- 11 PFS framing
- 12 PFS details
- 13 ITL framing
- 14 ITL details
- 15 ITL details
- 16 contact
- 17 distributors

www.panelite.us

NY : 212.947.8292
LA : 323.297.0115

PANELITE MAIN OFFICES

NEW YORK

PANELITE New York
315 West 39th Street, Studio 807
New York NY 10018
T: 212.947.8292 / F: 212.947.8489
www.panelite.us

LOS ANGELES

PANELITE Los Angeles
5835 Adams Boulevard
Culver City CA 90232
T: 323.297.0115 / F: 323.297.0122
www.panelite.us

©PANELITE LLC 2007
PANELITE™ LLC continues to improve its products through research and development and reserves the right to modify or change material in this brochure without notice. This is descriptive literature and does not constitute warranties, expressed or implied.



PANELITE DISTRIBUTORS



FLORIDA, USA

T-Concepts Miami

3995 North Miami Ave.
Suite 501
Miami, FL 33137
T: 305 576 5515
info@t-concepts.com
www.t-concepts.com

GEORGIA, USA

T-Concepts Georgia

2135 Devoor Hills Rd, Suite M
Atlanta, GA 30318
T: 404 351 2250 / 888 612 8203
F: 404 351 2280
info@t-concepts.com
www.t-concepts.com

AUSTRALIA

Baresque Architectural Finishes

53-55 Whiting St
Artarmon NSW Australia 2064
T: +612 9966 8470
F: +612 9966 8480
www.baresque.com.au

CHILE

Inter-Material SA

Cristian Petschen
Vitacura 2909, Of. 612
Santiago, Chile
T: (562) 435 0308
F: (562) 435 0308
www.inter-material.com

ITALY

Bencore SRL

Via S. Colombano, 9
54100 Massa - Italy
T: + 39 0585 830129
F: + 39 0585 835167
www.bencore.it

KOREA

World Formica

128-6, Nonhyun-dong, Kangnam-ku
Seoul, Korea
T: + 82 2 512 1144
F: + 82 2 511 0020
www.worldim.co.kr

HONG KONG

Super Star Company Ltd.

Flat A, 20/F Luk Hop Bldg.
8 Luk Hop Street
San Po Kong Hong Kong
T: 852 (2388) 9868
F: 852 (2388) 9998
www.superstar-hk.com

SWEDEN/NORWAY/DENMARK

Patrik Johansson

Panelite Sales: Sweden, Norway + Denmark
Rosenlundsgatan 18 11853
Stockholm Sweden
T: + 46 709 10644
F: + 46 865 84603
pjohansson@panelite.us

1. Various PANELITE™ panels • Panelite New York Showroom, New York, NY • Design: Panelite Photography: Panelite
2. PANELITE™ IGU/JC-8, PE/RC, WORKSTATION 2.0 Panelite New York Showroom, New York, NY Design: Panelite • Photography: Floto + Warner

3. PANELITE New York Showroom, New York, NY Design: Panelite • Photography: Floto + Warner
4. PANELITE New York Showroom, New York, NY Design: Panelite, Photography: Floto + Warner

